

PATRI  
CIALA  
**SCANO**  
DESIGN

EL DISEÑO,  
EN LOS OBJETOS,  
ES EL RASGO QUE  
TRASLUCE LO HUMANO,  
POR EL DETALLE,  
EL CRITERIO, EL HUMOR,  
LA ESTETICA,  
EL CARACTER, LA MANIA  
O LA OBSESION.

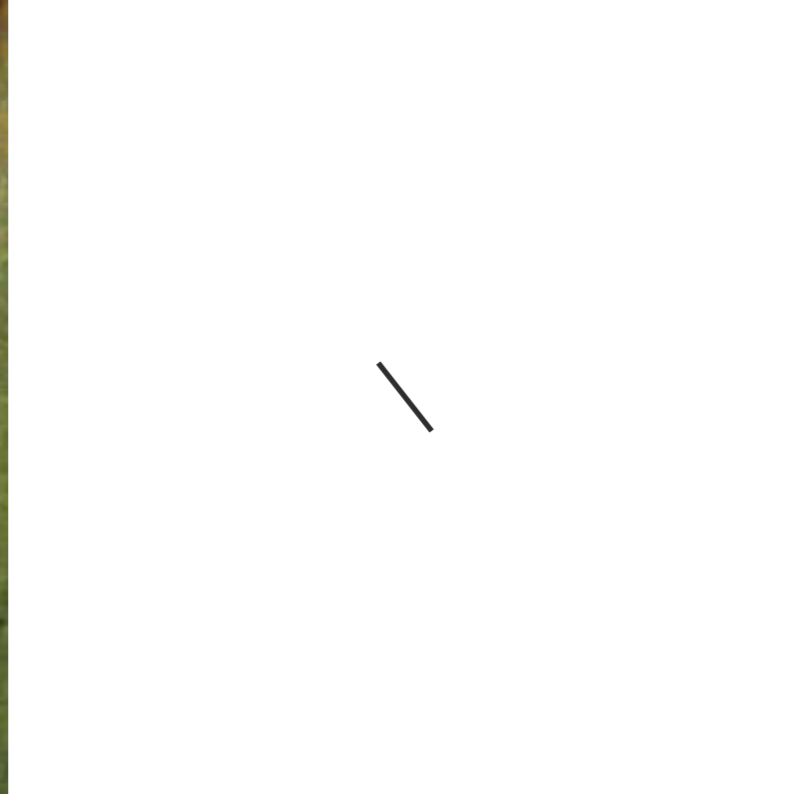
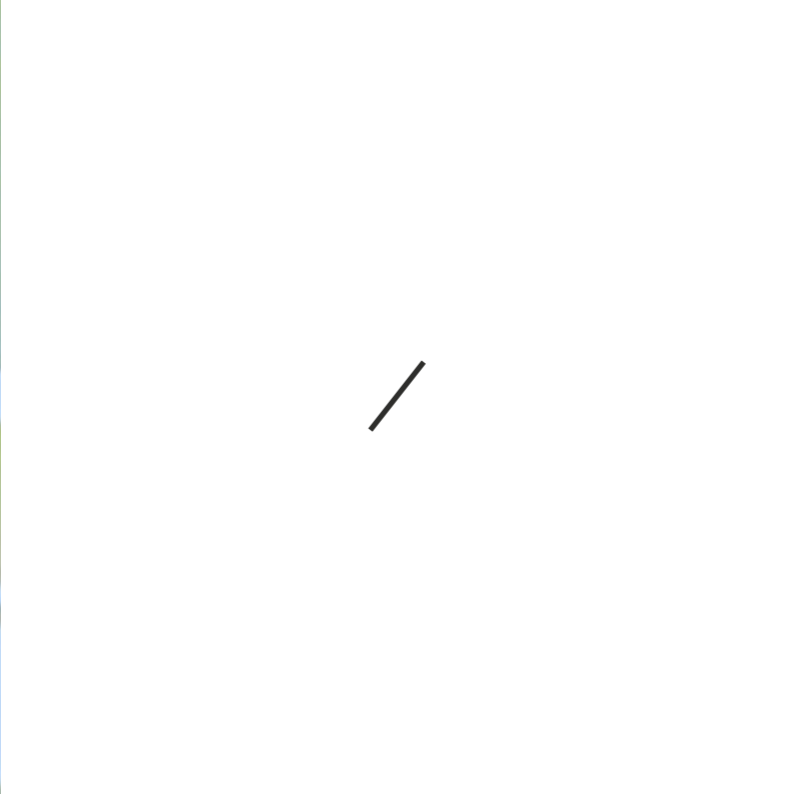

DESIGN, IN OBJECTS,  
IS THE THREAD THAT  
ILLUMINATES THE HUMAN  
ESSENCE, BY FINER DETAIL,  
CRITERIA, HUMOUR,  
AESTHETICS, CHARACTER AND  
OBSESSION.

SILLAS  
POLTRONAS  
CHAIRS  
ARMCHAIRS



## LUNAR

Lunar toma su forma a partir de cortes practicados a una estructura laminar cónica, el mullido interior orgánico resulta del fundido de la cáscara cónica con curvas ergonómicas. Año de diseño 2009.

Lunar gets its shape from cuts applied to a laminar conical structure, the organic volume with a soft surface results from melting the shell with ergonomic curves. Design year 2009.



LUNAR





LUNAR

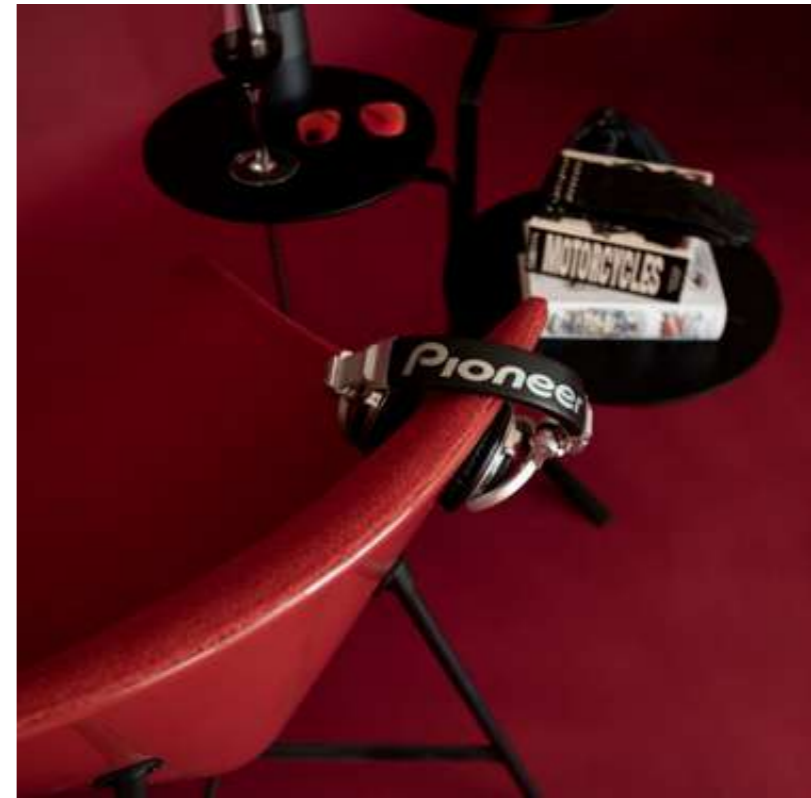



## SAKU

Poltrona de madera con asiento tapizado en un textil de poliéster y lino y un confortable respaldo de tiras de cuero entramadas. Año de diseño 2017.

Wooden deckchair, with an upholstered upholstered poliéster and linum textil seat textil seat and a comfrotable leather plaited strips backrest. Design year 2017.



SAKU









## SUD

Silla de madera maciza inspirada en las tipologías danesas que parten de los clásicos chinos. De morfología despojada, la U que forman el respaldo y los apoyabrazos encastrados es su rasgo distintivo. Tanto sus dimensiones, como la apilabilidad, la hacen apta para comedores, bares o restaurantes. Año de diseño 2013.

Solid wood chair. Inspired by the danish typologies, which are based on the chinese classics. With a stripped morphology, the U formed by the back jointed to the armrests its the most distinctive feature. The size and the fact of being stackable are ideal for bars and restaurants as well as dinning chairs. Design year 2013.



SUD









## ESTERO

Silla apilable. Ligera y confortable, su estructura de tubo de hierro viste un respaldo y asiento de cuero vacuno tensados por medio de correas y hebillas. Año de diseño 2019.

Stackable chair. Light and comfortable, its iron tube frame is dressed with a thick leather seat and back tightened by buckles and straps. Year of design 2019.



ESTERO











## SAUI

Silla de madera maciza de freijo, concebida a partir de los recursos locales del poblado de Trancoso, interior de Bahia, Brasil. Excelente mano de obra y tecnología básica. Consta de una estructura simple donde se apoyan un asiento y un respaldo de superficies complejas modelados a mano. Año de diseño 2011.

Solid freijo wood chair. Conceived making use of local resources from the village of Trancoso, located in the interior of the state of Bahia, Brazil. Basic technology and hand made excellence. It consists of a simple structure where the hand modeled complex surfaces of the seat and the endorsement rest. Year of design 2011.



SAUI



BANCOS

BANQUETAS

BENCHES

STOOLS



## XADRÉZ

Banco largo fabricado con maderas macizas.

Tonos naturales claros, rojizos y oscuros se unen desde la inspiración de la composición textil generando un damero rítmico estructural.

Año de diseño 2015.

Long solid wood bench. A variety of natural tones, lights, reddish and darks are mixed together creating a structural rhythmic checker inspired in textile composition. Design year 2015.



XADRÉS





## ZAC

Zac, banco. Sobre una estructura de varilla de hierro doblada y cromada se apoya el asiento, constituido por una lamina plegada, que juega con los planos logrando. Un apoyo confortable y una imagen minimalista. Año de diseño 2012.

Zac, stool. On a structure of bent chromed rod iron, lies The seat, consisting of a folded sheet. Playing with flat Surfaces it achieves to offer a comfortable seat and a Minimalist look. Design year 2012.



ZAC









## SIX

Banco hexagonal, elegante y minimalista. Concebido para espacios semi-públicos, su asiento tapizado en cuero posee seis caras que permite generar agrupaciones geométricas ocupando el mínimo espacio de forma ordenada. Año de diseño 2021.

Hexagonal bench, elegant and minimalist. Conceived for semi-public spaces, its leather upholstered seat has six sides that allow the generation of geometric groupings taking up a minimum space in an orderly way. Design year 2021.





## ZERO

Zero, banqueta ostenta el encanto de lo simple. Un fino asiento de madera maciza modelado con dobles curvaturas construido por ruteado con cnc 3d se apoya sobre una estructura de varilla de hierro doblada. Año de diseño 2012.

Zero, stool holds the elegance of simplicity. A thin solid. Wood seat, with double curvatures surfaces, was built by using 3d cnc router, rests on a chromed bent structure Of rod iron. Design year 2012.



ZERO





ZERO





ZERO





ZERO







## ZERO R

Banqueta con respaldo, un asiento y un respaldo, de madera maciza modelados con dobles curvaturas construidos por ruteado con cnc 3d se apoyan sobre una mínima estructura de varilla de hierro doblada. Año de diseño 2017.

Backrest stool a solid wood seat and backrest, with double curvatures surfaces, were built by using 3d cnc router. Both rest on a minimal chromed or epoxy painted bent structure of rod iron. Design year 2017.



ZERO R





## ESTERO

Banqueta ligera y confortable. Su estructura de tubo de hierro viste un respaldo y asiento de cuero vacuno tensados por medio de correas y hebillas. Año de diseño 2021.

Light and comfortable stool. It's iron tube frame is dressed with a thick leather seat and back tightened by buckles and straps. Design year 2021.



MESAS  
Y CONSOLAS  
TABLES AND  
CONSOLES



## MESA SUD

Mesa de comedor de madera maciza. Tapa de tablero alistonado, estructura liviana y patas conicas. Es producida en dos tamaños. Año de diseño 2014.

Solid wood dinning table. With a full lenght edge grain top, clean structure and conic legs. Is produced in two sizes. Design year 2014.



MESA SUD







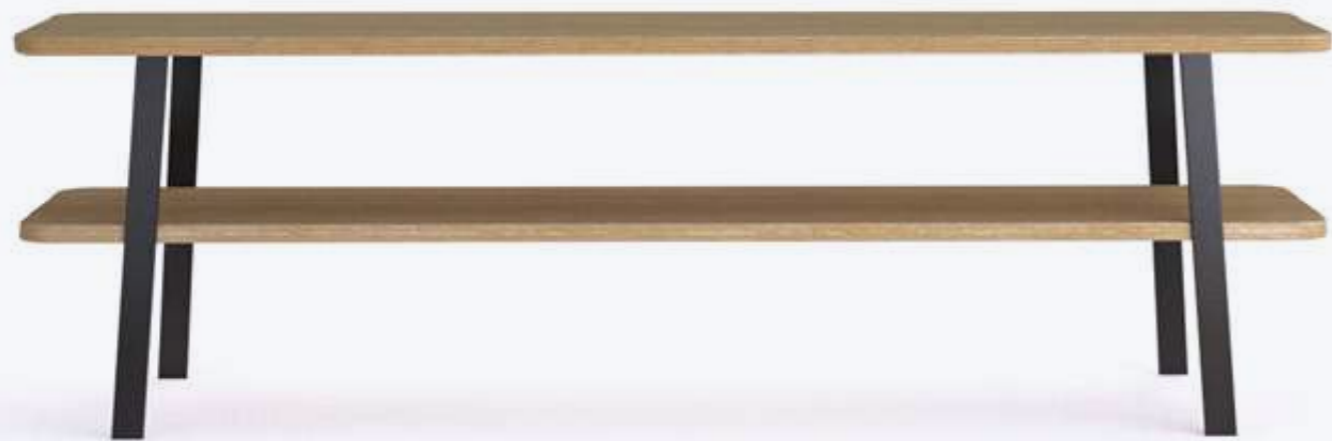

## HORMIGA

Dos largos tablonos de madera maciza descansan sobre una liviana estructura de hierro pintado.

Producida en dos alturas, la consola Hormiga funciona en variados contextos tales como living, comedores, escritorios, etc. Año de diseño 2017.

Two long solid wood planks rest on a lightweight painted iron frame. Produced in two heights, the Ant console works in several contexts such as living rooms, dining rooms, desks, etc. Design year 2017.



HORMIGA





## PLATZ

Partiendo desde la morfología de los elementos naturales, este trío de mesas bajas se caracteriza por sus tapas macizas de superficies suaves y curvaturas leves. El soporte es una estructura de hierro firme pero ligero visualmente. Sus tapas cóncavas son talladas en madera maciza utilizando tecnología de fresado tridimensional.

Año de diseño 2019.

Based on the natural elements morphology, this trio of low tables is characterized by solid smooth surfaces and slight curvatures. The support is an iron structure firm but visually lightweight. The concave lids are carved from solid wood using CNC milling technology. Design year 2019.



MESAS PLATZ

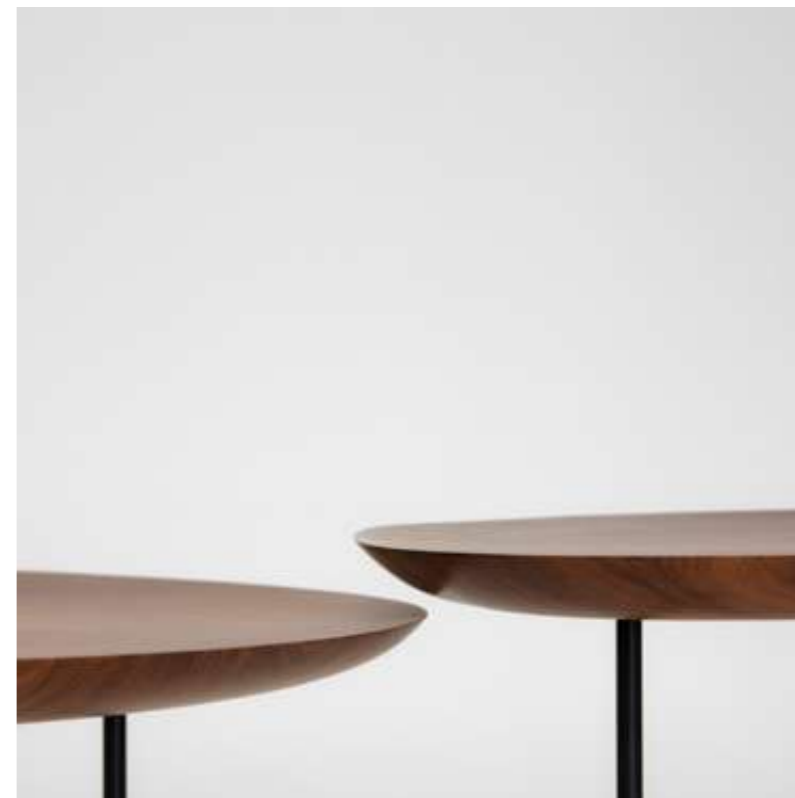



MESAS PLATZ





## PERSA

Inspirada en las estructuras de las plantas que distribuyen el peso en diferentes ramas esta mesa auxiliar ofrece tres superficies de apoyo a distintas alturas, que pueden ser utilizadas en espacios semipublicos o comerciales por 3 personas al mismo tiempo. Año de diseño 2018.

Inspired by the plants structures, that distribute the weight in different branches, this auxiliary table offers three support surfaces at different heights, which can be used in semipublic or comercial spaces by 3 people at the same time. Design year 2018.



PERSA





## ARAUCARIA

Mesa auxiliar que provee tres discos de apoyo independientes a distintos niveles permitiendo ser compartida por tres usuarios simultáneamente. Ideal para espacios privados, públicos, semipúblicos o comerciales. Año de diseño 2016.

A side table that provides three independent surfaces at different levels. Allowing to be shared for three users at any one time. Perfect for private, public, semipublic or commercial spaces. Design year 2016.





ARAUCARIA







## M A M B A

Dúo de mesas auxiliares. Las bases cónicas de madera maciza y los platos circulares se unifican a través de color generando piezas de volumetría clásica. Año de diseño 2019.

Side tables duo. The conic solid wood bases and the circular metal plates unify through color, building pieces of classical volumetry. Design year 2019.



MAMBA





## DUNAS S

Dúo de mesas auxiliares. En su base de tres patas de hierro pintado descansa una tapa de madera laqueada. Monocromáticas, atemporales y simples, las mesas Duna se adaptan con versatilidad a diversos espacios.

Año de diseño 2019.

Duo of nomad side tables. Over the three-legged painted structure of iron tube rests a lacquered wooden tabletop. Monochromatic, timeless and simple, Duna tables adapt to various spaces and situations in a versatile way. Design year 2019.



DUNAS S





## DUNAS M

Dúo de mesas bajas. Las tapas circulares de madera maciza descansan sobre una estructura metálica de tres patas. Elegantes y sólidas, las mesas Duna se adaptan a diversos espacios.

Año de diseño 2019

Low tables duo. The circular solid wood tops rest on a three-legged metal frame. Elegant and solid, the Duna tables adapt to different spaces.

Year of design 2019



DUNAS M

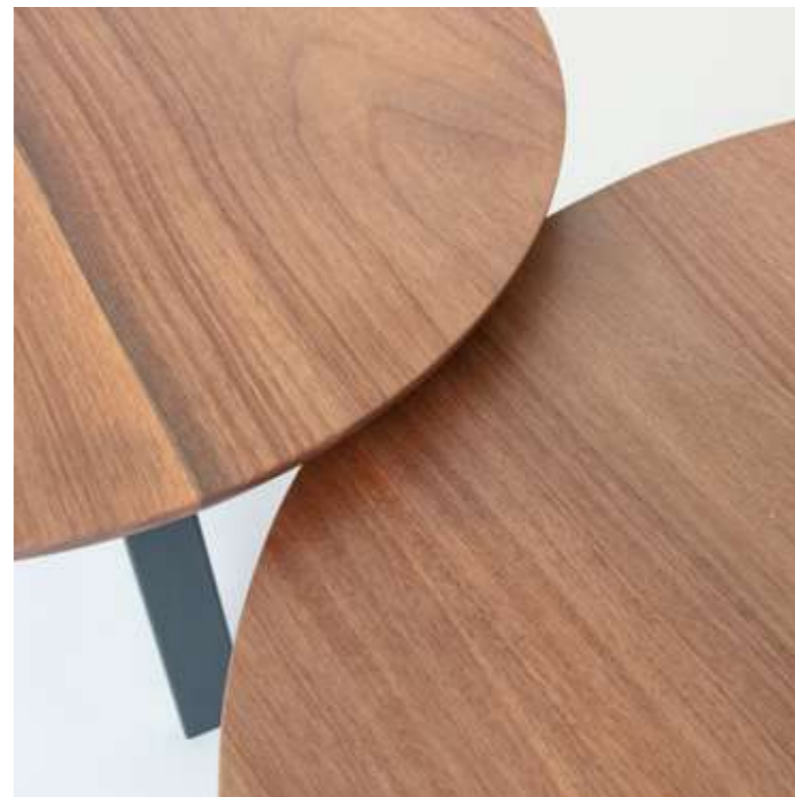





## DUNA G

Mesa baja provista de amplia tapa circular fabricada en madera maciza. Su estructura metálica de tres patas planas es sólida y elegante. Por su gran superficie esta mesa puede disponerse como mesa central tanto en un living como ambientando una recepción.  
Año de diseño 2021.

This elegant Low table , holds an attractive circular solid wood top and made with three flat legs. and a metal structure. This table can be used as a central table in a living room or a semi-public reception.  
Design year 2021.



DUNA G





## VAINILLA

*Mesa baja, fabricada en madera maciza de incienso y acabado lustre natural. De la familia Vainilla, la mesa completa el juego junto al sillón.*

*Año de diseño 2019.*

*Low table, entirely built with solid incense wood with natural luster finish. Due to its morphology Vainilla table suits the Vainilla couch.*

*Year of design 2019.*



MESA VAINILLA





## FIN

Mesa auxiliar originalmente diseñada para acompañar el lateral de un sofá sin brazos a la altura del asiento. Resulta en diferentes largos, versátil como apoyo, banqueta larga o pie de cama. Año de diseño 2021.

Side table with wooden top and steel base. Available in different lengths, they work as a good complement, to a sofa without armrests, an end bed bench or as a simple long bench. Design year 2021.



MESA FIN





## RASA 3

*Mesa redonda para 5 personas. Su base de tres patas de hierro se embute en la tapa de madera laqueada. Minimalista, monocromática y simple, la mesa Rasa 3 se adapta con versatilidad a diversos espacios. Año de diseño 2019.*

*Round table for 5 people. The three-legged steel frame is embedded into a lacquered wooden top. Minimalist, monochromatic and simple, the Rasa 3 table adapts in a versatile way to various spaces. Design year 2019.*



RASA3







## RASA 4

Mesa rectangular minimalista y simple. Su morfología rectangular permite reunir hasta diez personas cómodamente. La tapa de madera maciza de incienso se encastra en la estructura de hierro pintada. Año de diseño 2019.

Minimalist simple strong table. It allows up to ten seats. The solid wood top fits in the painted iron frame. Design year 2019.



RASA 4



SOFÁS,  
SILLONES  
Y POUFS

SOFAS,  
ARMCHAIRS  
AND POUFS



## VAINILLA

Sillón de dos cuerpos con estructura de madera maciza de incienso y terminación de lustre natural. Su juego de almohadones independientes están tapizados con un textil antimancha.

Año de diseño 2019.

Two seater couch with a solid incense wood frame with a natural luster finish. The set of independent cushions are upholstered with an anti stain treatment fabric. Design Year 2019.





## CAPIBARA

De volumetría redondeada, el sillón Capibara ofrece un espacio confortable donde relajarse.

Posee un flexible sistema modular que se adapta a diversos espacios, es ideal para espacios semipúblicos y privados. Año de diseño 2019.

With a rounded volumetry, the Capibara couch provides a comfortable space to relax.

Composed of two modules, it adapts to different contexts, being ideal for semi-public and private spaces. Design year 2019.



CAPIBARA

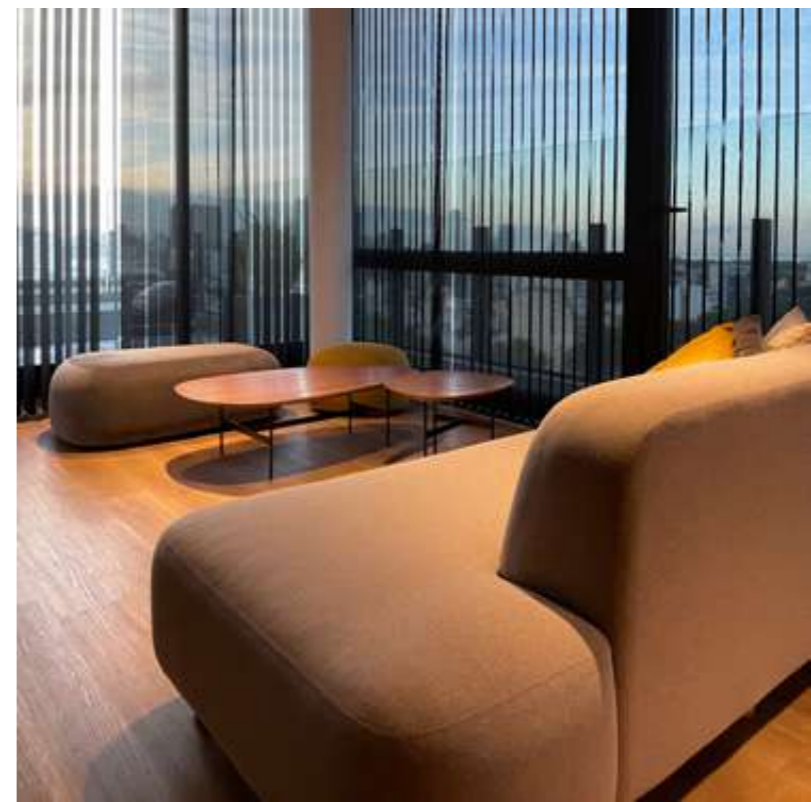



## PIRCA

Pirca es un conjunto de pufs en forma de paralelogramos irregulares que se pueden agrupar de diversas maneras generando distintas situaciones de uso y circulación. Su volumetría remite a la forma de las piedras erosionadas que, al agruparse, señalizan los caminos de la montaña. Funcionan tanto en espacios privados como públicos. Año de diseño 2016.

A set of irregular parallelograms, these pouf, can be organised in various ways to create different possibilities of use and circulation. Adaptable to not only private and public spaces. Design year 2016.





PIRCA





## ZELDA

Pouff modular pentagonal que evoca estructuras orgánicas posibilitando distintas configuraciones espaciales. Zelda se adapta tanto a espacios privados como públicos. Año de diseño 2016.

A modular pentagonal pouf inspired by natural structures, and offering a number of different design combinations. Design year 2016.







## COSMO

Pouffs circulares constituidos por un cojín tapizado contenido en una base metálica en cruz. Disponibles en dos tamaños, estos asientos se caracterizan por ser amplios y confortables. Elegantes y resistentes, pueden habitar el interior del hogar o espacios semi-públicos. Año de diseño 2021.

Circular pouffs made up of an upholstered cushion fitted in a metal cross base. Spacious and comfortable these seats are available in two sizes. Elegant and durable, they can be installed to brighten up home interiors or semi-public spaces. Design year 2021.



MOBILIARIO DE  
EXTERIOR  
OUTDOOR  
FURNITURE





## LIVING QUADRA

Living de exterior. Elementos como sillón, banco y mesa baja constituyen este conjunto. Las estructuras metálicas son pintadas con pintura poliéster y revestidas por listones de madera de lapacho laqueados. Los almohadones son confeccionados con lona acrílica con tratamiento UV. Año de diseño 2019

Outdoor living. Set composed of armchair, bench and rectangular low tables.

Lapacho wood planks backrest and seat rest on metallic structure. Suitable outdoor finishings were used for both cases, weatherproof lacquer polyester coated. The cushions are made of acrylic canvas with UV treatment. Year of design 2019



MESA CUADRA





POLTRONA QUADRA





LIVING QUADRA





## REPOSER A QUADRA

Reposera doble con respaldos reclinables. Cálida, ligera y minimalista, posee ruedas para facilitar el traslado. Su estructura de aluminio anodizado es revestida por listones de madera de lapacho tratados con laca para exteriores.

Año de diseño 2019.

Double chaise lounge with reclining backrests. Warm, light and minimalist, its wheels make it easy to move. Over the anodized aluminum structure lay the lapacho wood slats protected with outdoor lacquer. Design Year 2019.



REPOSERA QUADRA





## PERSA CHAPA

Inspirada en las estructuras de las plantas que distribuyen el peso en diferentes ramas esta mesa auxiliar ofrece tres superficies de apoyo a distintas alturas. Su terminación la hace apta para el uso en exteriores. Año de diseño 2018.

Inspired by the plants structures, that distribute the weight in different branches, this auxiliary table offers three support surfaces at different heights. Its termination makes it suitable for outdoor use. Design year 2018.

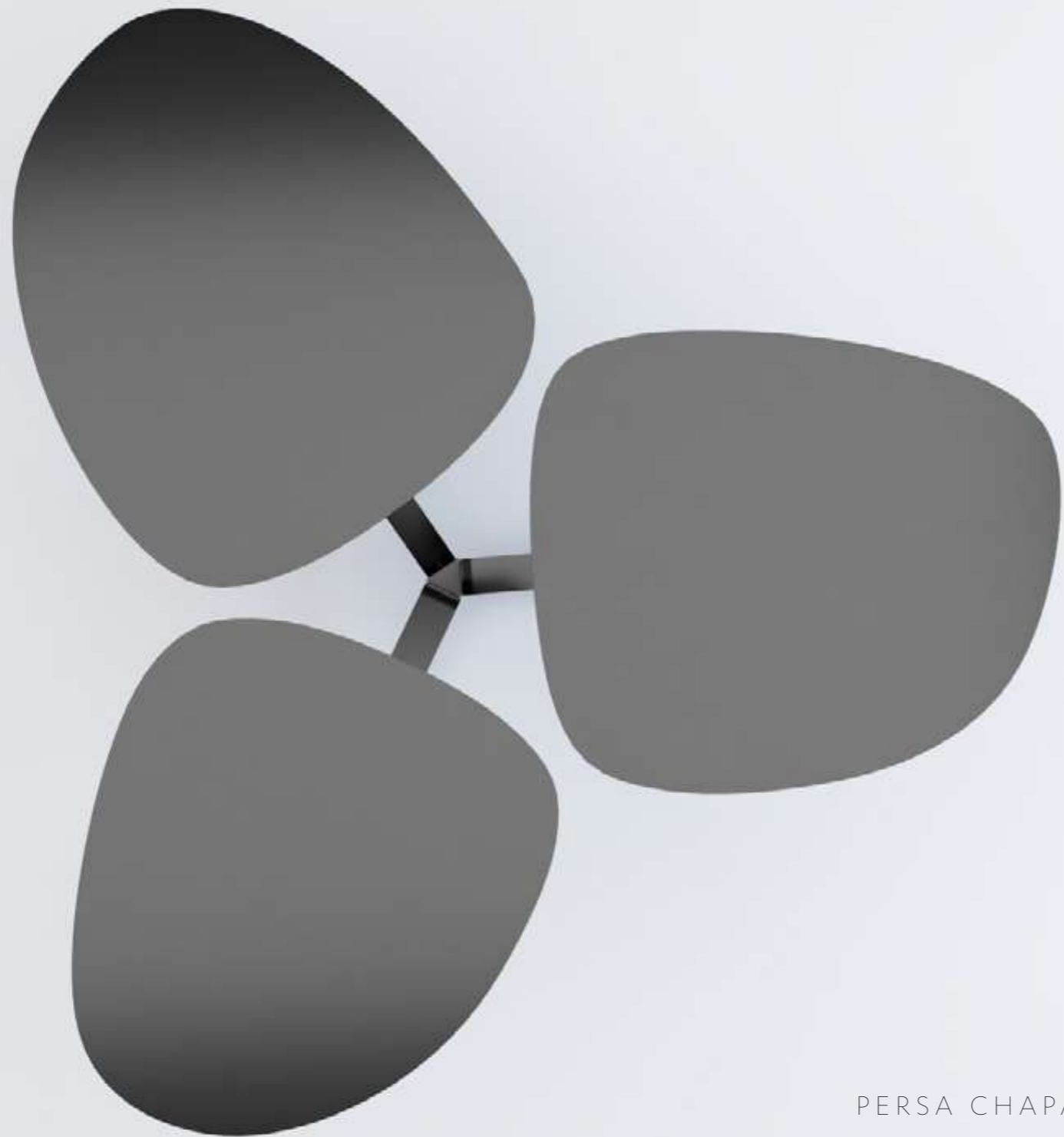

PERSA CHAPA







## LIVING LAGOA

Lagoa es una familia de piezas compuesta por mesa, sillón y pufs. Concebida para exterior, la colección posee una estructura de metal tubular recubierta con pintura poliéster y almohadones confeccionados con lona acrílica Sunbrella®. Las superficies de apoyo son de chapa calada laser para el drenaje del agua.

Año de diseño 2020

Lagoa is a family of pieces composed of a table, armchair and pufs. Conceived for outdoor use, the collection has a tubular metal frame coated with polyester paint and cushions made from Sunbrella® acrylic canvas. The support surfaces are made of laser cut sheet metal for water drainage. Design Year 2020



SILLON LACOA





POUF LAGOA





MESA LAGOA



ILUMINACIÓN  
LIGHTING



## BARQUILLO

De gran tamaño, el conjunto de lámparas tiene una presencia escultórica dónde las cintas de bambú trenzado matizan con su trama el paso de la luz generando un clima cálido y agradable.

En su desarrollo y producción dialogan lo artesanal y la tecnología. Año de diseño 2019.

Large in size, the lamp set has a sculptural presence, where braided bamboo ribbons nuance the passage of light creating a warm and pleasant climate. Handicraft manufacture dialogue with technology in the development and production.

Design year 2019.



BARQUILLO



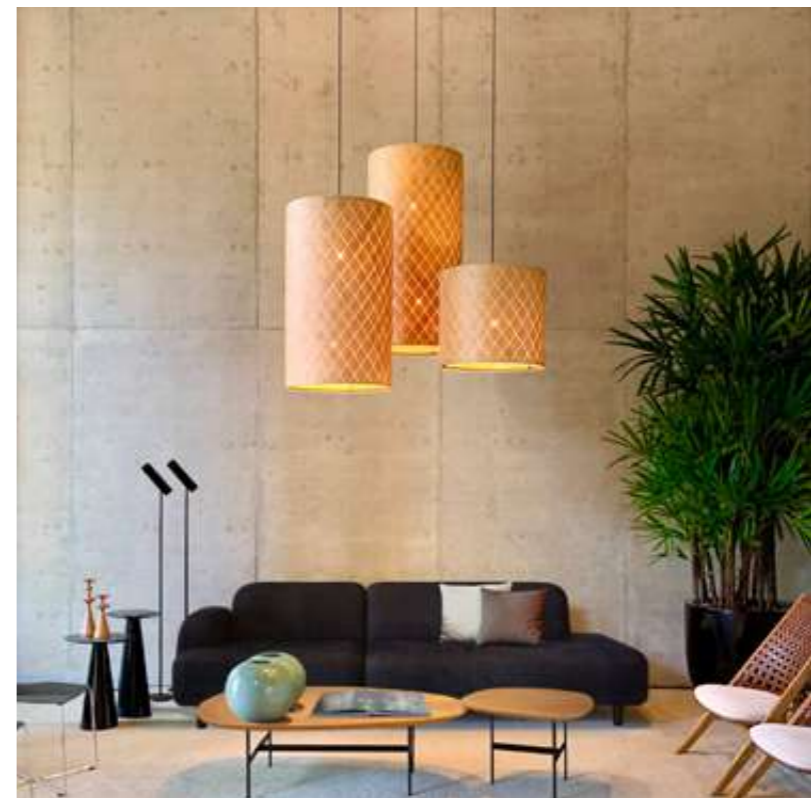
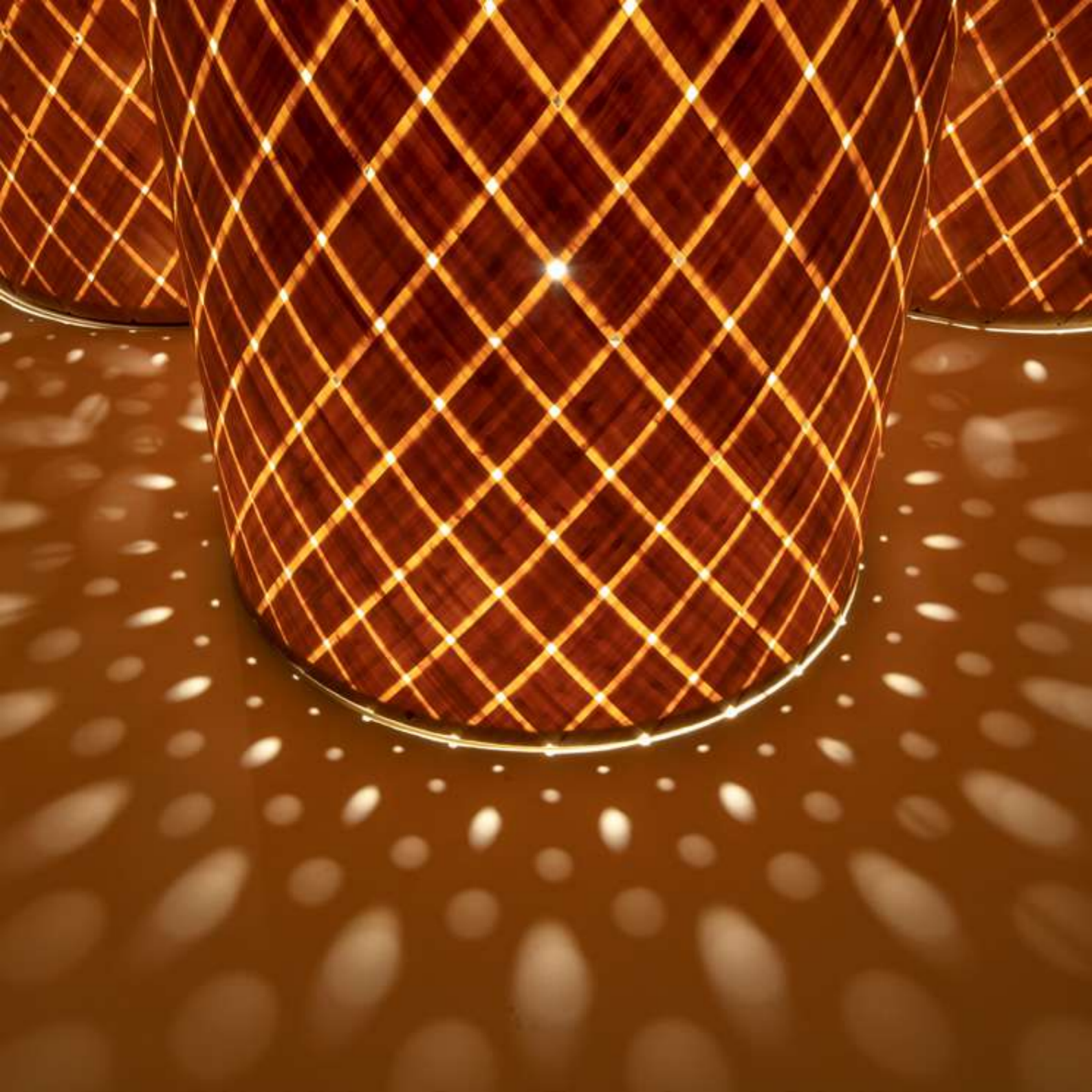





## BARQUILLO

Lámpara de pie elaborada con cintas de bambú trenzado que matizan el paso de la luz. Sostenida por una estructura metálica de amplia base, su pantalla ilumina y genera un clima cálido y agradable. En su desarrollo y producción dialogan lo artesanal y la tecnología. Año de diseño 2021.

Floor lamp made with braided bamboo ribbons that soften the passage of light. Supported by a metallic structure with a wide base, its lampshade illuminates with a warm and pleasant climate. Handicraft manufacture dialogue with technology in the development and production. Design year 2021.



BARQUILLO DE PIE





## HALO

Llenos y vacíos, Halo es una lámpara colgante que se caracteriza por su gran diámetro. Su pantalla fina y texturada es protagonista, la luz que emite el anillo ilumina rasante el paso de la trama. La lámpara puede dimerizarse remotamente. Fuente de iluminación led. Año de diseño 2019.

Full and empty, Halo is a ceiling lamp characterized by its large diameter. The thin textured screen is the protagonist, the light emitted by the ring brightens the pattern's steps. The light can be remotely dimmed. Led lighting source.

Design year 2019.



HALO









## TAN TAN

Lámparas colgantes de vaqueta. Utilizando los métodos de talabartería tradicional, dos piezas de vaqueta conformadas se vinculan mediante costuras. Compactas en tamaño, de iluminación cálida, Tan Tan pueden instalarse unitariamente o agrupadas. Año de diseño 2019.

Ceiling leather lamps. Using the traditional saddlery methods, two shaped leather pieces are sewn together. Compact in size, warm lighting, Tan Tan can be set by itself or in group. Year of design 2019.



TAN TAN







## GIRANDA

Artefacto de iluminación escultórico, se destaca por su interior iluminado y las sombras que arroja. Ideal para halls, dobles alturas o espacios que requieran la generación de un clima cálido y particular  
Año de diseño 2022.

Sculptural pendant light, distinguished by its illuminated interior and the shadows it casts. Ideal for lobbies, double-height spaces, or areas seeking to evoke a warm and unique atmosphere.  
Year of design 2022.





## XALÁ

Lámpara de mesa. Genera un clima cálido y amable gracias a su pantalla de bambú translúcida que contrasta con una sólida base de madera maciza. Año de diseño 2023.

Table lamp. It creates a warm and inviting atmosphere. The translucent bamboo shade contrasts beautifully with a sturdy, solid wood base.\*<br/>Year of design 2023.





## TITAN CALYPSO

Antorchas de led constituidas por una sucesión de discos de acrílico separados por anillos de aluminio que permiten a la luz encapsulada escapar por los espesores de los discos iluminándolos. Alimentadas e electricidad, las lamparas de led rgb a control remoto admiten la programación del color en todo el espectro tanto como efectos de fundido a distintas velocidades. Incluyen una base redonda para interiores y una estaca para su uso exterior. Año de diseño 2009.

Titan and calypso, watertight led torchs built by a succession of acrylic discs separated by aluminium rings that allow the light to escape through the thickness of the discs illuminating them. The remote control commanded rgb led lamps are colour programmable and include a fade effect with variable speed. Year of design 2009.



TITAN CALYPSO



COMPLEMENTOS  
ACCESSORIES



## TRIP

Perchero de pie, funcional, simple y ligero.

Su estructura de tres patas esta fabricada con planchuela de hierro curvado pintada con cobertura al horno. Año de diseño 2019.

Coat stand, functional, simple and visually clean.

The tripod structure is made of curved/bended iron strip finished with epoxy powder coat paint.

Design year 2019.







## PLATZ

Partiendo desde la morfología de los elementos naturales, este trío de tablas de servir ofrece superficies suaves y curvaturas leves, para presentar y compartir alimentos en la mesa. Tallados en madera maciza utilizando tecnología de fresado tridimensional. Año de diseño 2017.

Thought from the morphology of the natural elements, this trio of serving tables offers soft surfaces and slight curvatures, perfect to present and share food on the table. Carved in solid wood using three-dimensional milling technology. Design year 2017.



PLATZ









## MACUMBA

Candelabros. Inspirados en la cultura afrobrasileña, tres piezas de madera torneadas de diferentes alturas y morfologías análogas, invitan a pedir deseos. Año de diseño 2014.

Candle holders. Three lathed wooden pieces of different heights and similar morphologies. Year of design 2014.



MACUMBA









## YUPI

Candelabros. Explorando las posibilidades de la cerámica, tres piezas de diferentes alturas y morfologías análogas, permiten armar diferentes composiciones. Año de diseño 2014.

Candle holders. Exploring the possibilities of glazed ceramic, three pieces of different heights and similar morphologies, allow different combinations. Year of design 2014.



YUPI







## PRENDE

Candelabro, sujeta la vela usando la morfología funcional de un broche. Año de diseño 2014.

Candle holder. Holds the candle using the functional morphology of a brooch. Year of design 2014.



PRENDE





## H A R E M

Cesta conformada a partir del plegado de una delgada lamina metalica cuyos calados se inspiran en las composiciones geometricas islamicas. Sus pliegues se vinculan a traves de broches de colores. Año de diseño 2014.

Basquet, that consists in a folded metal sheet, wich perforations are inspired by the islamic geometric compositions. Its folds are linked through color snaps. Year of design 2014.



HAREM

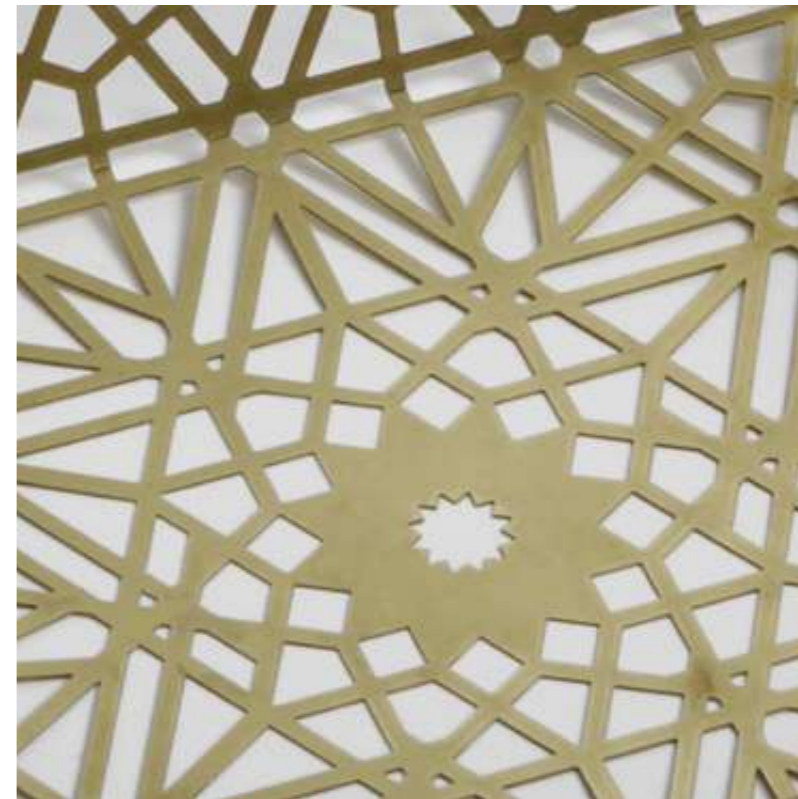



## TALEGA

Frutero. Permite también una correcta ventilación y preservación a partir de minimizar la superficie de contacto entre el contenido y el contenedor. Su condición cóncava y una arquitectura casi naval, recuerdan una cesta tradicional. Año de diseño 2006.

Fruit dish. Minimizing the contact surface between fruits and container, lets a correct ventilation and fruit preservation. Its concave form contrasts the material rigidity and an almost naval architecture remember a traditional basket. Year of design 2006.





TALEGA





## RONDA

Parrilla para chimeneas. Parrilla para asar carnes y verduras en chimeneas con brasas de leña o carbón. El movimiento giratorio permite regular su altura y acercar los alimentos durante la cocción. Ronda es desmontable. Año de diseño 2002.

Ronda, chimney grill. Vegetables and meat chimney grill, with firewood live coals and carbon. The revolving movement lets regulate its height and to approach the foods during the baking. Ronda is collapsible. Year of design 2002.



RONDA



INVESTIGACIÓN  
Y DESARROLLO  
RESEARCH AND  
DEVELOPMENT



## BRAVA

Montura de polo, combina tecnología y talabartería artesanal. Con una innovadora estructura descubierta de fibra de carbono, es liviana, libera de carga la columna del caballo y se desmonta para el recambio de partes. Año de diseño 2018.

Polo saddle, combines quality and traditional craftsmanship. With an innovative naked structure, its lightweight carbon fiber frame, frees the spine of the horse from its load and it is dismountable to replace pieces. Design year 2018.



BRAVA





BRAVA



# FICHAS TÉCNICAS



SILLAS  
POLTRONAS  
CHAIRS  
ARMCHAIRS

LUNAR | Poltrona | Chair

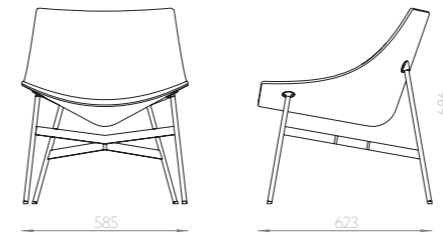

Prfv, espuma de poliuretano inyectada, cuero y hierro cromado.

Laminated grfp, injected polyurethane foam, leather and chromed iron.

SAKU | Poltrona | Chair

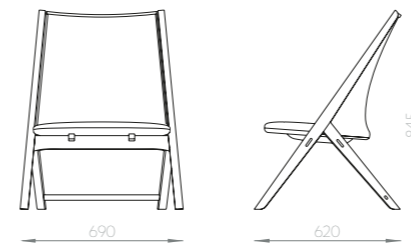

Estructura de madera - respaldo de cuero trenzado. Asiento tapizado en textil antimanchas..

Wood structure. Woven natural leather backrest. Textile upholstered seat.

SUD | Silla | Chair

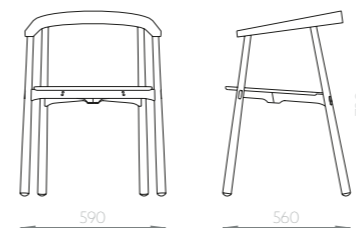

Madera jequitiba. Lustre poliuretánico natural.

Pink jequitiba solid wood. Natural polyurethane lacquer finish.

ESTERO | Silla | Chair

---

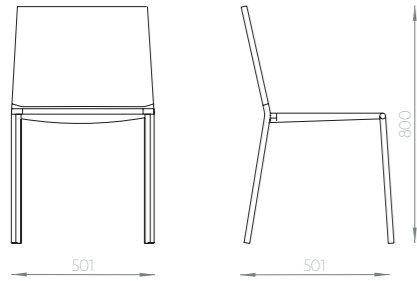

Estructura de hierro pintado con pintura epoxi negra semi mate, funda de cuero natural, hebillas de hierro cromado.

Iron structure painted with semi-matt black epoxy paint, natural leather cover, chrome-plated iron buckles.

SAUI | Silla | Chair

---

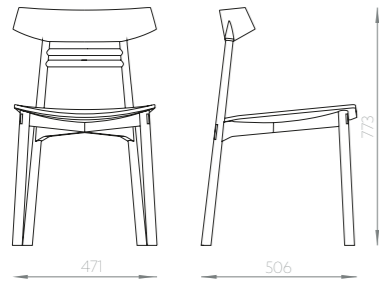

Madera maciza de freijo. Comercializada unicamente en Brasil

Solid freijo wood . Available only in Brasil

XADRÉS | Banco | Bench

---

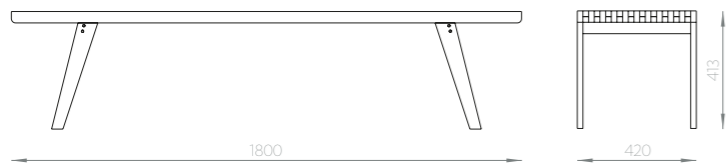

Listones de madera de lenga, lapacho, guatambú, guayubira y cedro misionero. Terminación: laca poliuretánica.

Wood ribbons of lenga, lapacho, guatambú, guayubira and missionary cedar. Finish: polyurethane lacquer.

BANCOS  
BANQUETAS  
BENCHES  
STOOLS

ZAC | Banco | Stool

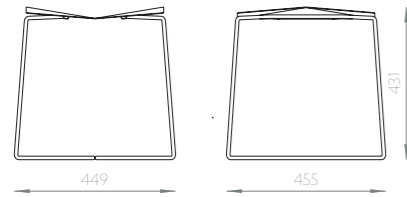

Asiento de chapa de hierro plegado, tapizado, en cuero y base de hierro cromada.

Iron sheet seat folded, leather and chromed Iron base.

ZERO | Banco | Stool

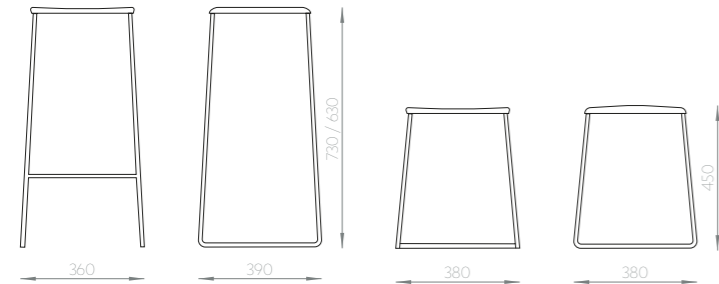

Asiento de tablero de lenga mecanizado y estructura de hierro cromada o pintada con pintura Epoxi.

Seat of machined lenga wood and structure of Chromed iron or epoxy podwer coated.

ZERO R | Banqueta | Backrest stool

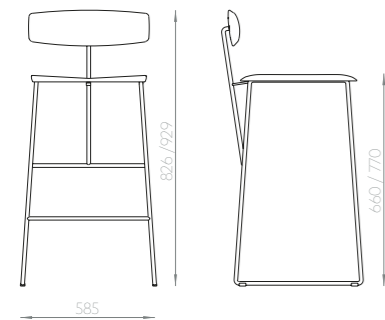

Asiento y respaldo de lenga mecanizado y estructura de hierro cromada o pintada con pintura epoxi.

Seat of machined lenga wood and structure of chromed or epoxy painted iron.

ESTERO | Banqueta | Backrest stool

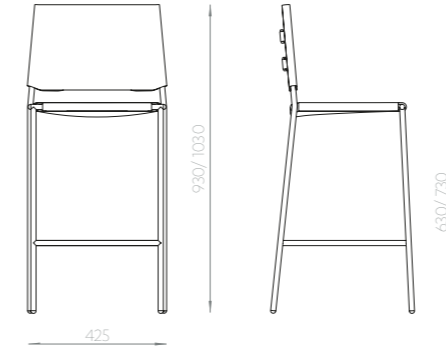

Estructura de hierro terminación pintura homeable. Asiento y respaldo realizado en talabartería a partir de cuero natural.

Metal frame, epoxy finish. Seat and backrest made of natural leather.

XADRÉS | Banco | Bench



Listones de madera de lenga, lapacho, guatambú, guayubira y cedro misionero. Terminación: laca poliuretánica.

Wood ribbons of lenga, lapacho, guatambú, guayubira and missionary cedar. Finish: polyurethane lacquer.

SIX | Banco | Stool

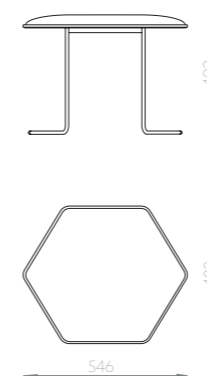

Estructura de hierro y asiento realizado en talabartería a partir de cuero natural.

Metallic structure with epoxy finish, natural leather.

MESAS  
Y CONSOLAS  
TABLES AND  
CONSOLES

MESA SUD | Mesa de comedor | Dining table

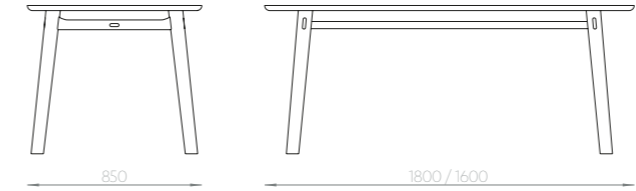

Madera de lenga (ar) o tauari rojo (br)  
Lenga wood (ar) or red tauari wood (br)

HORMIGA | Mesa larga auxiliar | Long auxiliar table

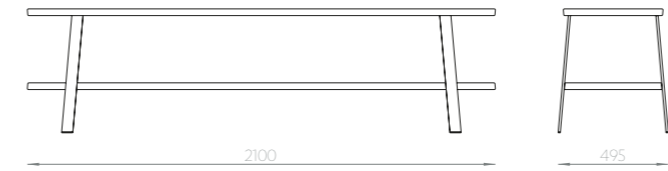

Estructura de hierro y tablas de madera de lenga o jequetiba mecanizada 3d.  
Lenga wood and iron structure.

MESAS PLATZ | Mesas | Tables

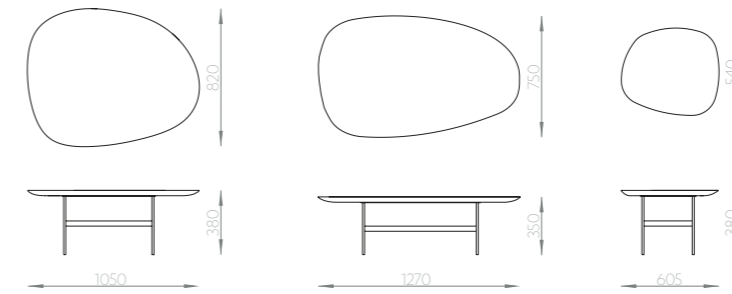

Estructura de hierro y tapa de madera de jequetiba mecanizada 3d.  
Jequetiba wood and iron structure.

PERSA | Mesa auxiliar | A side table

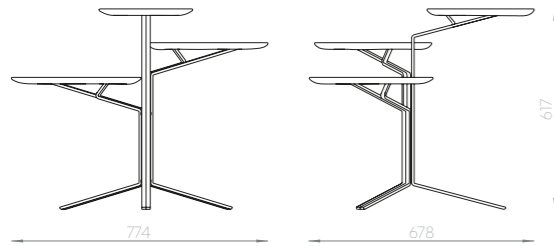

Tapas de jequitiba mecanizadas 3d y posteriormente laqueadas. Estructura de hierro pintada con pintura epoxi.

3d machined wood tops of poliurethane lacquer mdf and epoxi podwer coated iron structure.

ARAUCARIA | Mesa auxiliar | A side table

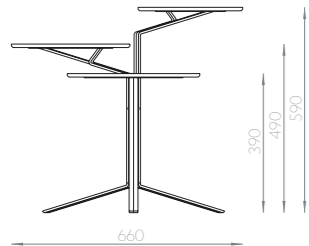

Discos de mdf laqueado y estructura de hierro pintada con pintura epoxi.

3d machined wooden tops finished with poliurethane lacquer and epoxi podwer coated iron structure.

MAMBA | Mesa auxiliar | A side table

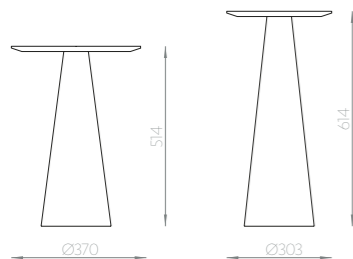

Base de madera tornada y tapa en mdf mecanizado 3d, ambas terminadas con laca poliuretánica. Breda de hierro pintada con pintura epoxi y

Wooden base and 3d machined mdf tops finished with poliurethane lacquer. iron union piece covered with epoxy paint.

DUNA S | Mesas auxiliares | Side tables

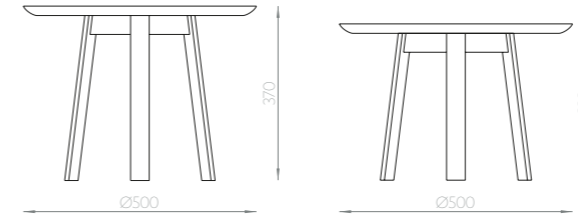

Tapas de mdf mecanizadas 3d y posterioremnte laqueadas con pintura poliuretánica. Estructura de hierro pintada con pintura epoxi.

3d machined wooden tops finished with poliurethane lacquer and epoxi podwer coated iron structure.

DUNA M | Mesas bajas | Low tables

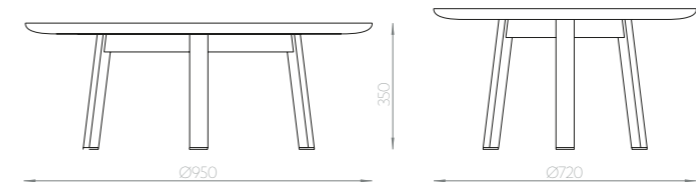

Tapas de mdf mecanizadas 3d y posterioremnte laqueadas con pintura poliuretánica. Estructura de hierro pintada con pintura epoxi.

3d machined wooden tops finished with poliurethane lacquer and epoxi podwer coated iron structure.

DUNA G | Mesa baja | Low table

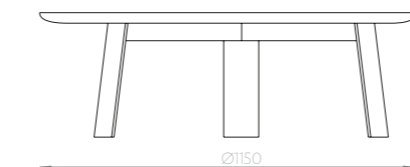

Madera maciza de incienso. Terinación:laca poliuretánica. Estructura de hierro pintada con pintura epoxi.

Solid incense wood. Finishing: polyurethane lacquer and. epoxi podwer coated iron structure.

RASA4 | Mesa de comedor | Dinning table

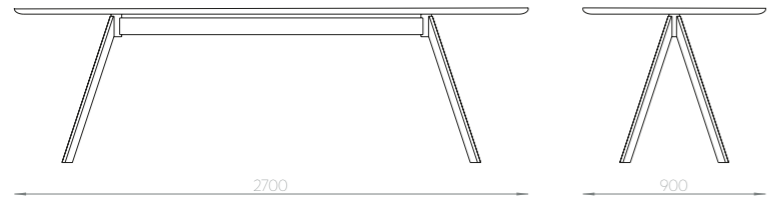

Tapa de mdf mecanizada 3d y posterioremnte laqueada con pintura poliuretánica. Estructura de hierro pintada con pintura epoxi.

3d machined wooden top finished with poliurethane lacquer and epoxi podwer coated iron structure.

RASA3 | Mesa de comedor | Dinning table

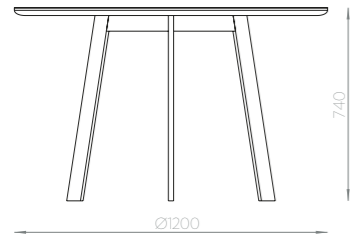

Tapa de mdf mecanizada 3d y posterioremnte laqueada con pintura poliuretánica. Estructura de hierro pintada con pintura epoxi.

3d machined wooden top finished with poliurethane lacquer and epoxi podwer coated iron structure.

VAINILLA | Mesa baja auxiliar | Low auxiliar table

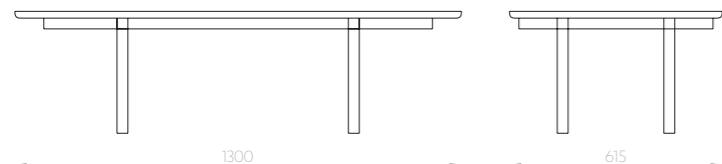

Madera maciza de incienso. Terinación:laca poliuretánica.

Solid incense wood. Finishing: polyurethane lacquer.

MESA FIN | Mesa auxiliar | A Side table

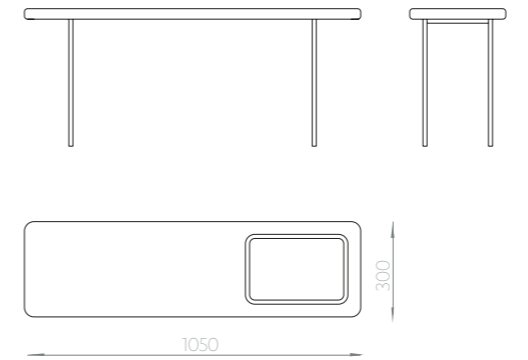

Tapa de madera maciza de paraíso mecanizada 3d y posterioremnte lustrada con poro abierto color negro. Estructura de hierro pintada con pintura epoxi.

3d machined wooden top finished with poliurethane lacquer and epoxi podwer coated iron structure.

SOFÁS,  
SILLONES  
Y POUFS  
SOFAS,  
ARMCHAIRS  
AND POUFS

VAINILLA | Sofá | Sofa

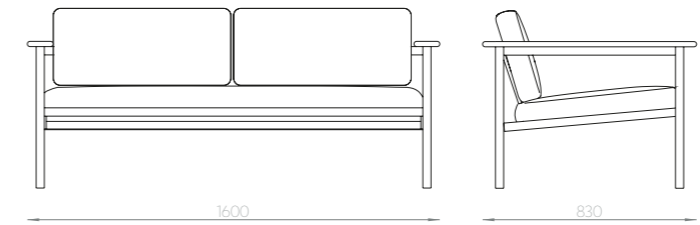

Madera maciza de incienso protegida con laca poliuretánica. Almohadones de espuma de poliuretano y cobertura de acrotop tapizados con genero de alto conotendo de poliester y tratamiento antimancha.

Solid incense wood. Finishing: polyurethane lacquer. Polyurethane foam cushions and acrotop cover upholstered with a high polyester content and anti-stain treatment.

CAPIBARA | Sofá | Sofa

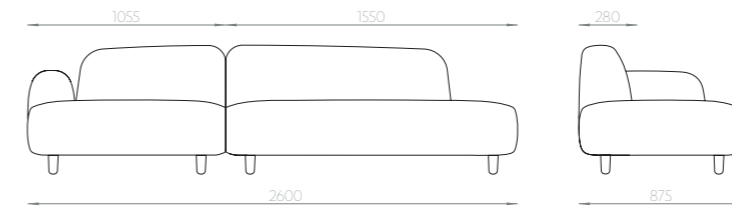

Estructura interior de madera maciza de saligna , espuma de poliuretano de alta densidad y patas de lenga torneada. Tapizado en chenille de lino y alto contenido de poliester.

Solid saligna wood , high density poliurethane foam and lenga lathed legs , upholstered with linum and poliester chenille.

COSMO | Pouff | Pouf

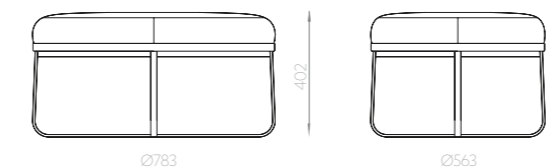

Tapizado con blindaje antimanchas, estructura de hierro terminación epoxi.

Upholstered with anti-stain textile, epoxy finished iron structure.

PIRCA | Pouff modular paralelogramos | A modular parallelograms pouf

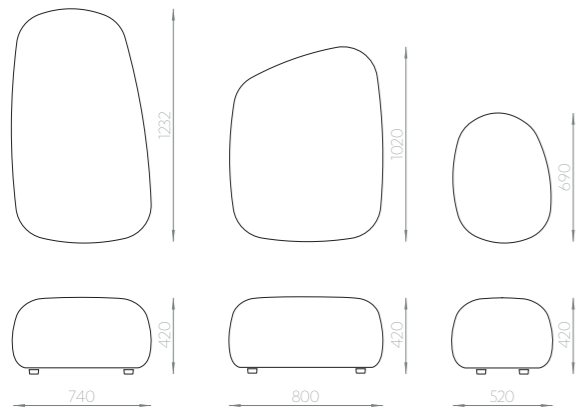

Madera maciza , espuma de poliuretano de alta densidad y patas de lenga torneada y tapizados en chenille de lino y alto contenido de poliester.

Solid saligna wood , high density poliurethane foam and lenga lathed legs , upholstered with linum and poliester chenille.

ZELDA | Pouff modular pentagonal | A modular pentagonal pouf

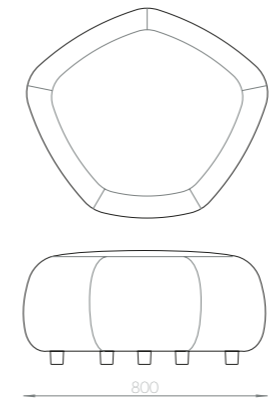

Estructura interior de madera maciza de saligna , espuma de poliuretano de alta densidad y patas de lenga torneada y tapizados en chenille de lino y alto contenido de poliester.

Solid saligna wood , high density poliurethane foam and lenga lathed legs , upholstered with linum and poliester chenille.

Configuraciones | Configurations

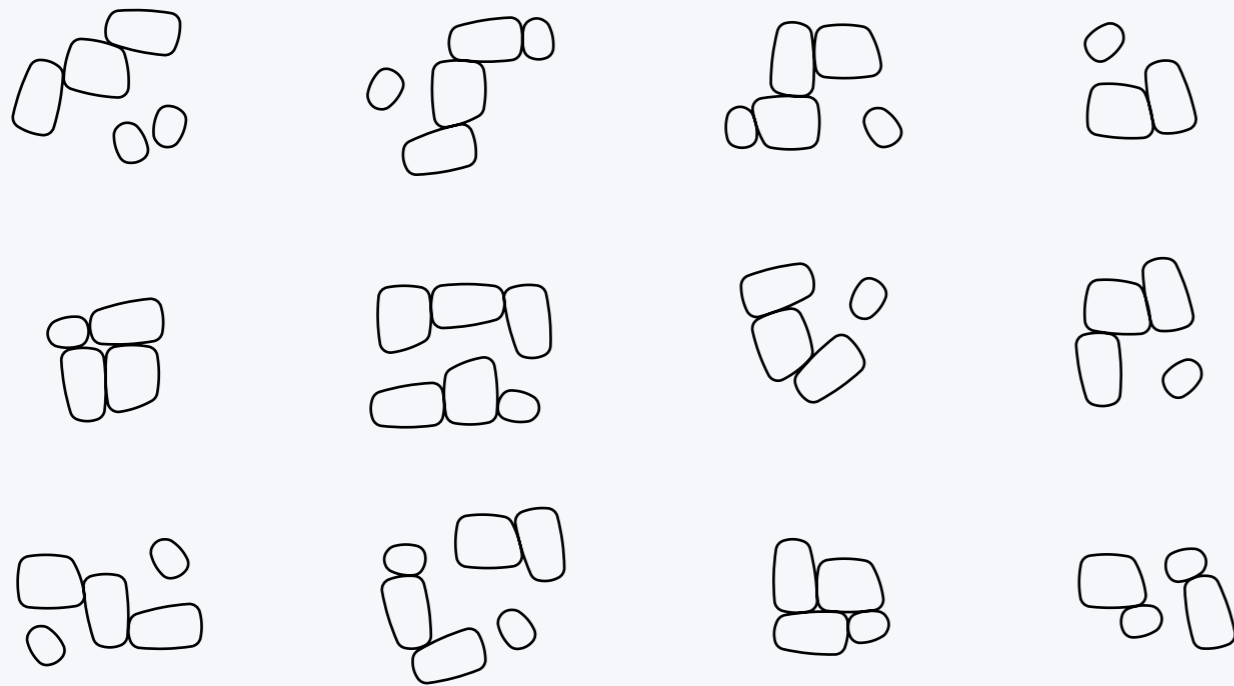

Configuraciones | Configurations

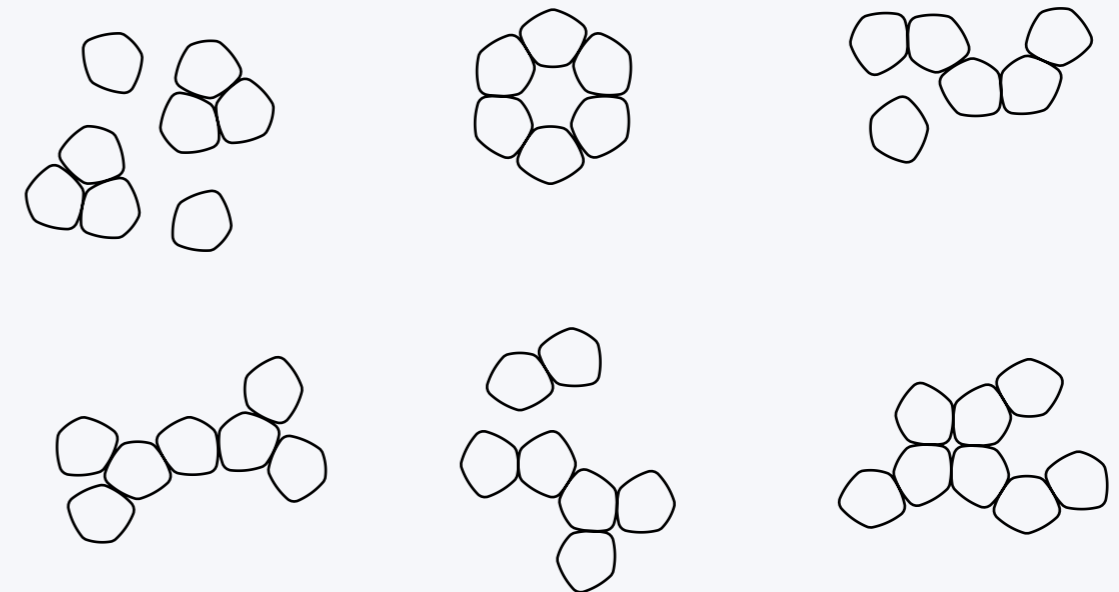



MOBILIARIO DE  
EXTERIOR  
OUTDOOR  
FURNITURE

QUADRA S I Sillón I Armchair

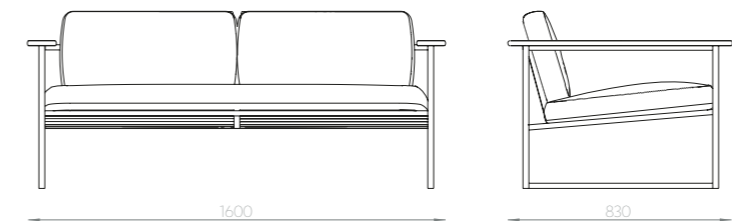

Estructura de hierro pintada con pintura epoxi. Listones de lapacho y almohadones de espuma de poliuretano tapizados con lona acrílica.

Epoxi podwer coated iron structure. Lapacho slats and polyurethane foam cushions upholstered with acrylic canvas.

QUADRA M I Mesa baja I Low table

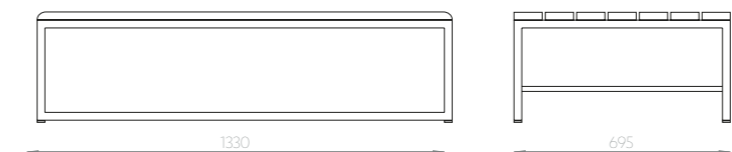

Estructura de hierro pintada con pintura epoxi. Listones de lapacho protegidos con laca para exteriores.

Epoxi podwer coated iron structure. Lapacho slats protected with lacquer for outdoors.

QUADRA P I Poltrona I Chair

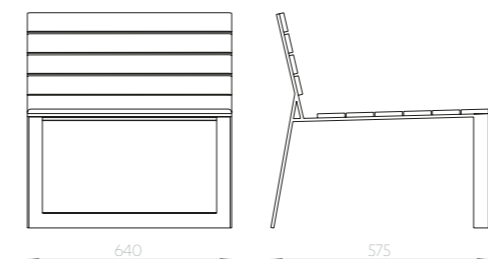

Estructura de hierro pintada con pintura epoxi. Listones de lapacho protegidos con laca para exteriores.

Epoxi podwer coated iron structure.  
Lapacho slats protected with lacquer for outdoors.

QUADRA RD | Reposera doble | Double Chaiselongue

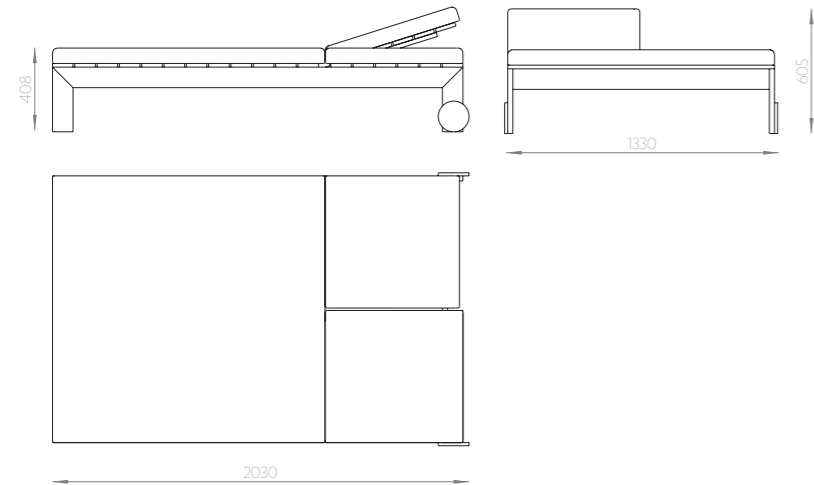

Estructura de aluminio pintado con pintura poliéster.  
Listones de lapacho protegidos con laca para exteriores.  
Colchonetas de espuma de poliuretano tapizadas con lona vinílica.

Poliester powder coated aluminium structure.  
Lapacho slats protected with lacquer for outdoors.  
Polyurethane foam mats upholstered with vinyl canvas.

ARAUCARIA | Mesa auxiliar de exterior | Outdoor side table

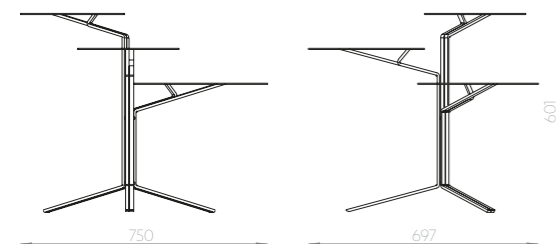

Estructura de hierro pintado con pintura poliéster.  
Poliester powder coated iron structure.

LAGOA S | Sillón | Armchair

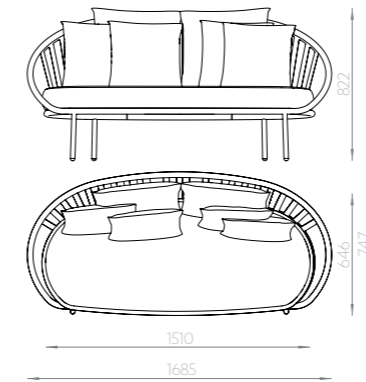

Estructura metálica terminación pintura poliéster,  
colchoneta de asiento y cojines de respaldo  
fabricados con género de Sunbrella®. Tubular metal  
frame coated with polyester paint and cushions made  
from Sunbrella® acrylic canvas.

LAGOA P | Pouff | Pouf

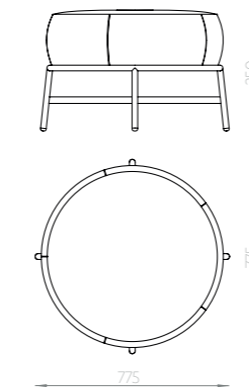

Estructura metálica terminación pintura poliéster,  
asiento fabricado con género de Sunbrella®

Tubular metal frame coated with polyester paint and  
cushion made from Sunbrella®.

LAGOA M | Mesa auxiliar de exterior | Outdoor side table

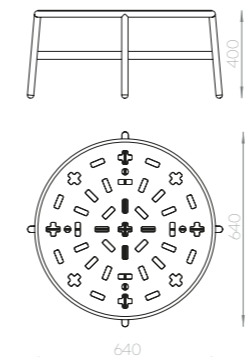

Estructura metálica terminación pintura poliéster.  
Tubular metal frame coated with polyester paint.

# ILUMINACIÓN LIGHTING

## BARQUILLO | Lámparas colgantes | Pendant Lamp

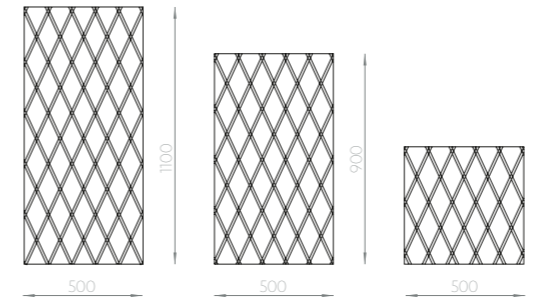

Tiras de chapa de bambú terminadas con laca poliuretánica. Estructura de hierro pintado con epoxi horneable. Lámparas led (zócalo E27).

Bamboo veneer strips finished with polyurethane lacquer. Epoxy powder coated iron structure. Led lamps (socket E27).

## HALO | Lámpara colgante | Pendant Lamp

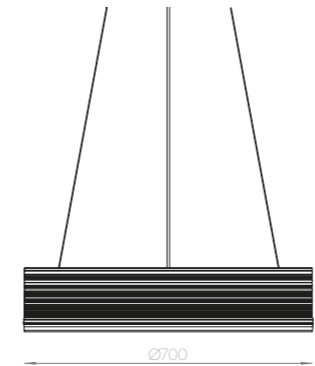

Pantalla de PP revestido con vinilo de Vescom. Estructura de hierro y aluminio pintado con pintura epoxi microtexturada. Plafón luminoso de led con transformador 220v.

Vescom vinyl-coated PP display. Iron and aluminum structure painted with micro-textured epoxy paint. Led luminous ceiling light with 220v transformer.

## TAN TAN | Lámparas colgantes | Pendant Lamp

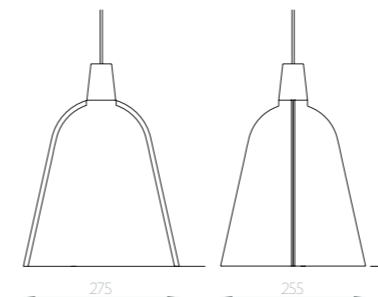

Cuero natural. Madera de lenga.  
Lámpara led (zócalo E27).

Natural cow leather. Lenga wood.  
Led lamp (socket E27).

GIRANDA | Lámparas colgantes | Pendant Lamp

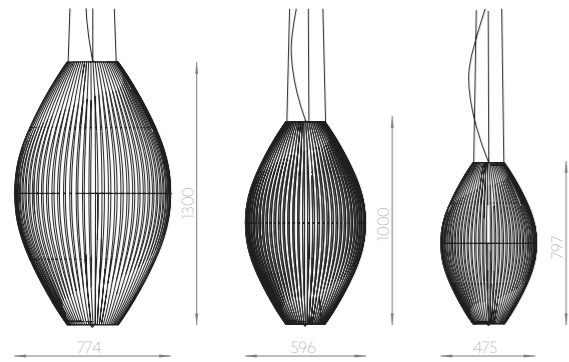

Estructura de hierro pintada con epoxi al horno. Varillas de kiri terminación laca poliuretánica natural. Lámparas AR111.

Powder-painted iron structure. Natural polyurethane lacquer finish kiri wood rods. AR111 lamps

TITAN CALYPSO | Antorchas de led | Watertight led torchs

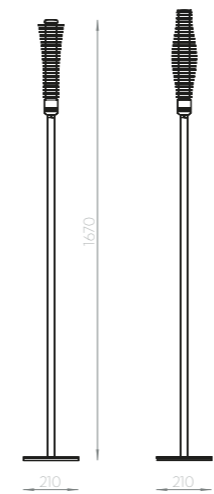

Sucesión de discos de acrílico separados por anillos de aluminio.

Succession of acrylic discs separated by aluminium rings.

BARQUILLO DE PIE | Lámpara de pie | Floor lamp

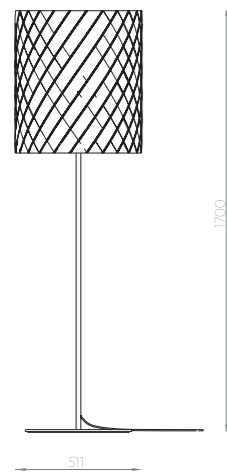

Chapa de bamboo. Estructura metálica terminación epoxi metalizado semimate.

Bamboo veneer, metal structure, semi-matte black epoxy finish.

XALÁ | Lámpara de mesa | Table Lamp



Pantalla de chapa de bamboo, base de paraíso torneada, iluminación con 1 foco E27.

Bamboo veneer shade. Solid wood base.  
Led lamp (socket E27).

# COMPLEMENTOS ACCESSORIES

RONDA | Parrilla para chimeneas | Chimney grill

---

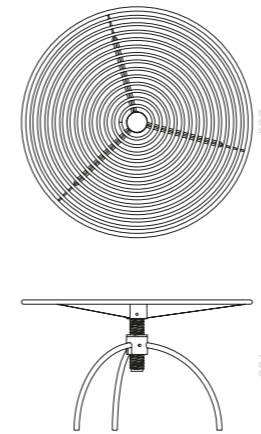

Hierro con acabado de teflon.

Iron with teflon finishing.

TRIP | Perchero | Standing coat rack

---

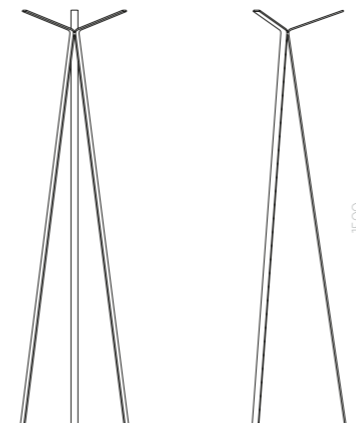

Estructura de hierro pintada con pintura epoxi.

Epoxy powder coated iron structure.

PLATZ | Trío de tablas | Trio of serving tables

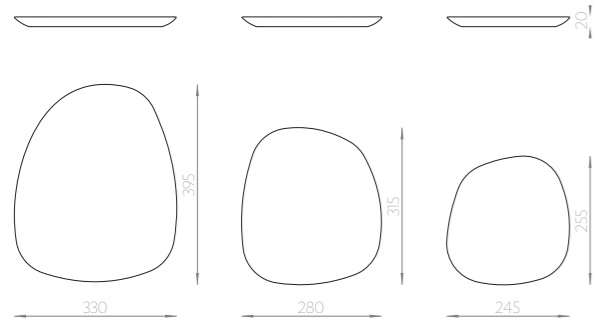

Madera maciza

Solid wood

MACUMBA | Candelabros | Candle holders

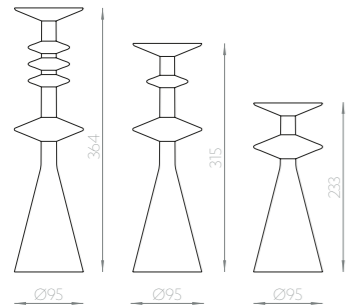

Tres piezas de madera

Three lathed wooden

YUPI | Candelabros | Candle holders

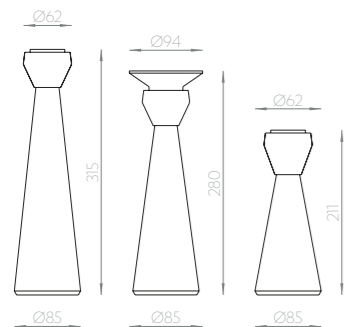

Ceramica

Ceramics

PRENDE | Candelabros | Candle holders

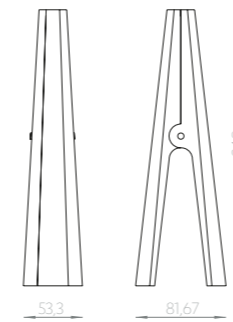

Chapa de hierro plegada con acabado cobre, bronce o cromado o acabado con pintura epoxi.

Folded iron sheet, copper, brass, or chrome finishings or powder coat finishing.

HAREM | Cesta | Basket

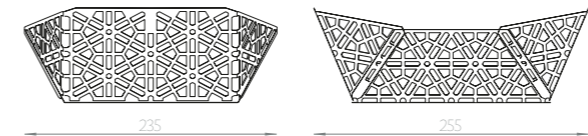

Doblando una delgada lámina de metal

Bending a thin sheet of metal

TALEGA | Frutero | Fruit dish

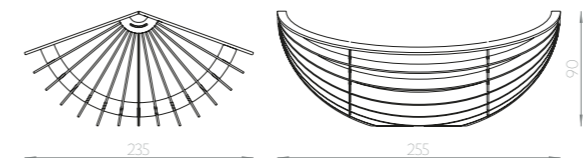

Latón semiduro con plateado cromo-níquel y madera laminada de cedrillo. Otro modelo que e so latón semiduro con plateado cromo-níquel.

Nickel chrome plating mild brass and local cedrillo. Another model that is nickel chrome plating mild brass.

INVESTIGACIÓN  
Y DESARROLLO  
RESEARCH AND  
DEVELOPMENT

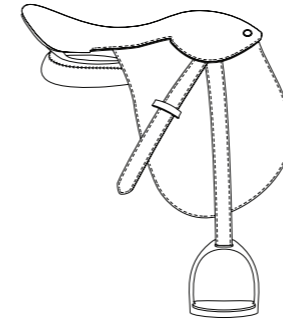

Cascara e estructura de fibra de carbono laminada bastos y cojín colados de espuma de poliuretano, base del asiento en gel de poliuretano y bastos y cojín tapizados en cuero y faldas de suela.

Laminated carbon fiber shell and frame, molded polyurethane foam panels and cushion seat, seat base in polyurethane gel, leather upholstered seat and panels, and sole flaps.



## PATRICIA LASCANO

Diseñadora Industrial egresada de la UNLP / Universidad de La Plata, Argentina, donde nació y creció.

Funda Estudio Lascano en Buenos Aires en 2001.

Su producción, de un estilo claro, despojado y directo, es difícil de clasificar. La diversidad de tipologías que aborda, con diversas características y materiales se unifica en un lenguaje racional, donde luce su extrema atención al detalle.

El de Patricia Lascano es un diseño detallista. En su visión contemporánea y desprejuiciada conviven ítems tradicionales como una parrilla para hogar o una montura de polo high tech, propuestas que innovan en cuanto a usos y lenguajes así como muestran también su interés por las costumbres y saberes que se decantan de generación en generación. Lo particular en Lascano también es cómo se anima a abordar esos temas con nuevas tecnologías.

Patricia Lascano entiende al diseño en los objetos "como el rasgo que trasluce lo humano, ya sea por el detalle, el criterio, el humor, la estética, el carácter la manía o la obsesión". Sus piezas de diseño son producidas y comercializadas en Argentina y en Brasil.

Participó en varios concursos, exhibiciones y ferias nacionales e internacionales. Casa FOA, DAC en el Museo Fortabat, en el MAMbA, en el CC Borges, CC Recoleta, en el Marq, Puro Diseño, Museo Sivori, Proyecto Deseo, Premio Mad MNAD, D&D+DARA, Espacio Kalpakian, CCK areas Vip del Festival Baremboim, etc.

Así como 100 % Design Tokio, 100% Design London, DMY Berlín, Museo de Artes Decorativas de Frankfurt, Salón de Diseño en Brasil, Meet my project Paris, BID, Central de Diseño de Matadero Madrid, DAC, Museo de las Artes de Guadalajara, Bid, Madrid, Meet my project Milán y Din Design In Milan.

Convocada por diversas entidades para brindar charlas, entre ellas el Festival CDU Diseño de Uruguay, UP Palermo, DArA Semana del Diseño entre otras.

Varios de sus productos han sido premiados y otros son parte de la Colección de Diseño Argentino del Museo de Arte Moderno de Buenos Aires (MAMbA). Muchos de ellos obtuvieron el Sello del Buen Diseño y la Etiqueta CMD.

Industrial Designer, graduated from the Facultad de Bellas Artes, University of La Plata, Argentina, where she was born and raised.

She started her own Studio in Buenos Aires in 2001.

With a direct, clear and stripped style, her production, it is difficult to classify. The diversity of typologies, materials and features she deals with, unifies into a rational language, where an extreme attention to detail brights.

Lascano's design is full of details. On her unprejudiced contemporary view, traditional items like a fireplace grill, or a high tech Polo saddle share their place; her proposals innovates not only in applications as in languages, and reveal her interest in the customs and knowledges that catalyze from a generation into the next. What is also particular is how Lascano deals with the new technologies.

Patricia Lascano understands design in objects, as the thread that illuminates the human essence, by finner detail, criteria, humour, aesthetics, character and obsession. Her designs are produced and comercialized in Argentina and Brazil.

She has has been part of several competitions, exhibitions and national and international fairs. Casa FOA, DAC at Fortabat Museum, at MAMbA, CC Borges, CC Recoleta, Marq, Puro Diseño, Sivori Museum, Proyecto Deseo, Premio Mad MNAD, D&D+DARA, Espacio Kalpakian, CCK Festival Baremboim Vip areas, etc.

She also attended 100 % Design Tokyo, 100 % Design London, DMY Berlin, Museum of Decorative Arts in Frankfurt and Salão Design in Brazil, Meet my project in Paris and DAC, Museo de las Artes de Guadalajara, Bid Madrid, Meet my project Milan, Din Design In Milan.

Patricia gave talks at the CDU Design Festival in Uruguay, UP Palermo, DArA Design Week, among others.

Her products have several awards and some of them are part of the Argentine Design Collection of the Museum of Modern Art in Buenos Aires (MAMbA). Many of them obtained the Sello del Buen Diseño and the Etiqueta CMD.



PATRI  
CIALA  
SCANO  
DESIGN



[www.estudiolascano.com](http://www.estudiolascano.com) | [info@estudiolascano.com](mailto:info@estudiolascano.com)

Paraguay 610 | Piso 19 | C1057AAH | Ciudad Autónoma de Buenos Aires | Argentina | +54.11.4515.0445 | 4.984.178